

MAX LOAD = 1/4 TON - 1 FALL - BODY DOWN - HOOK SUSPENSION

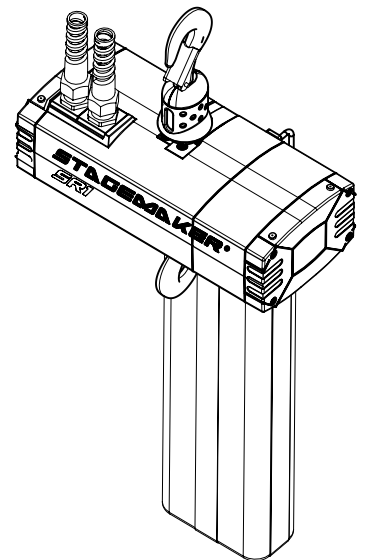
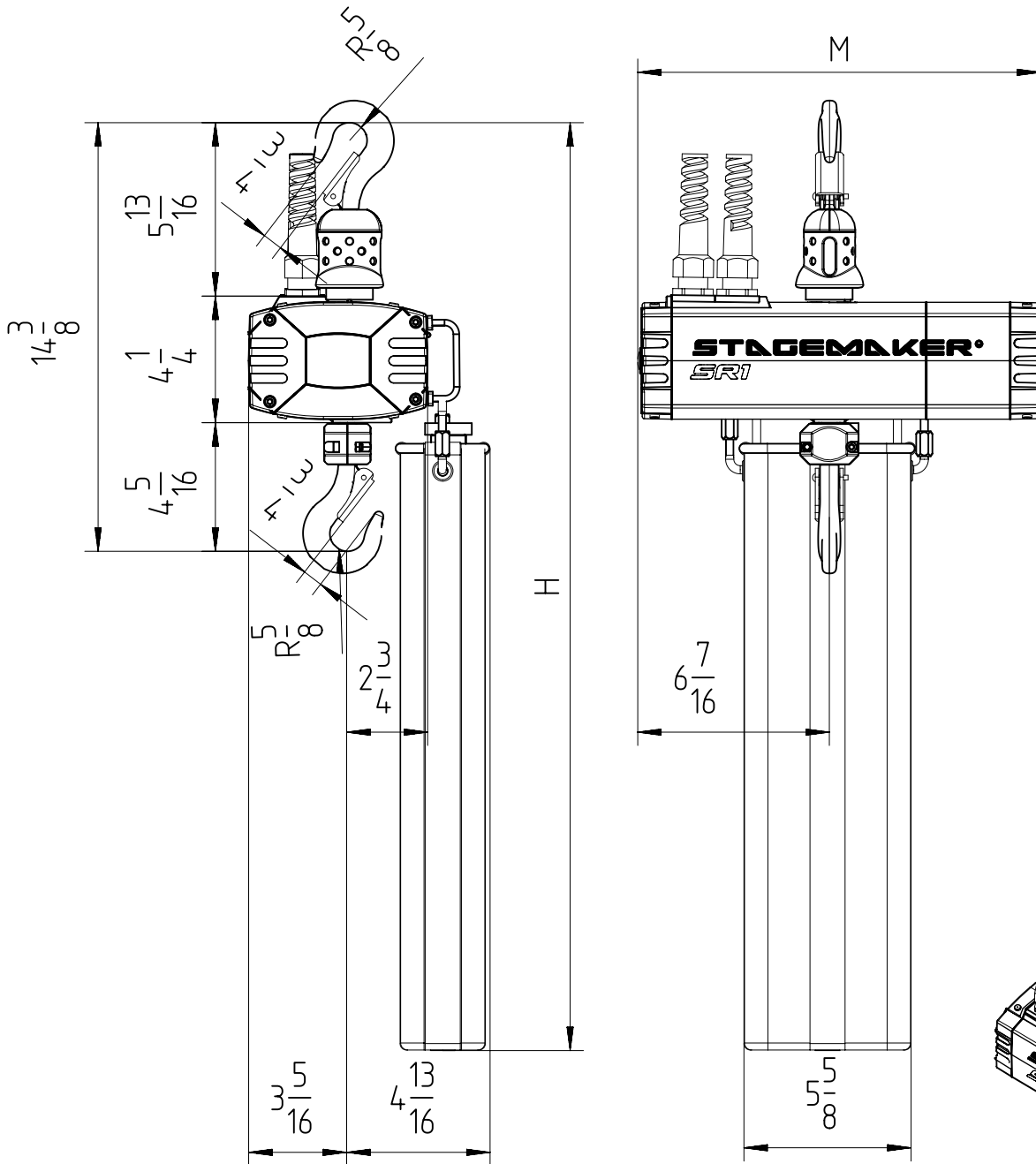

Chain Size	Max Load [ton]	Chain Bag Capacity [ft]	Chain Weight [lbs/ft]	Dimension H [inches]	Estimated Unit Weight Wo Chain [lbs]	
					SB	DB
4x11	$\frac{1}{4}$	52	0.25	$23 \frac{3}{4}$	22.9	25.8
		65		$25 \frac{3}{4}$	22.9	25.8
		98		$31 \frac{1}{4}$	22.9	25.8
Dimension M [inches]					$12 \frac{1}{8}$	$13 \frac{1}{2}$

SB : Single Brake
DB : Double Brake