

MAX LOAD = 1/2TON - 2 FALLS - BODY UP - HOOK SUSPENSION

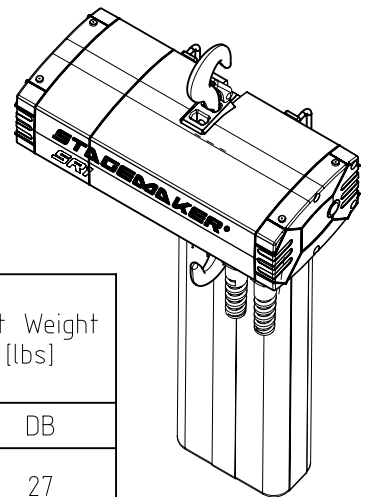
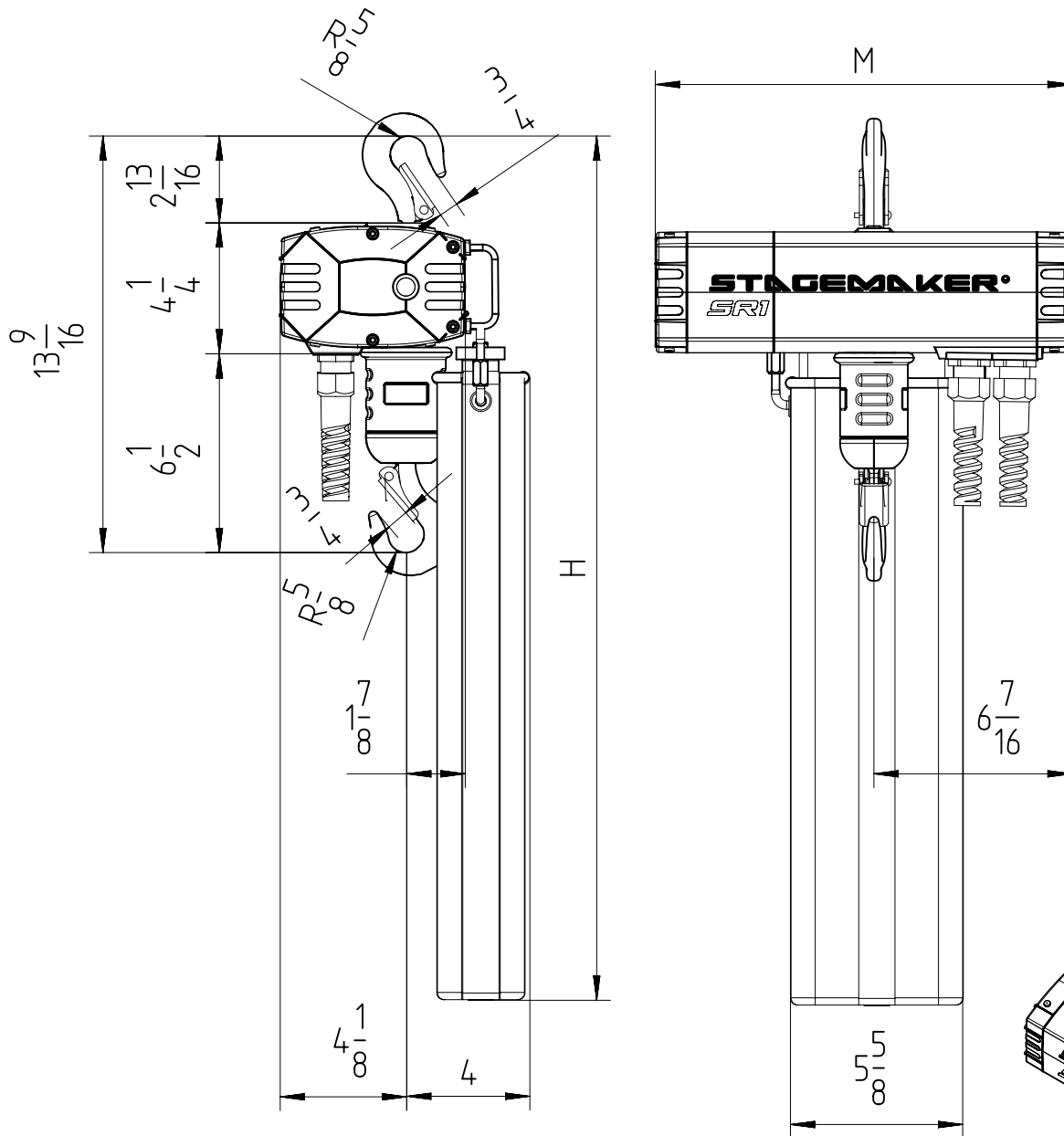

Chain Size	Max Load [ton]	Chain Bag Capacity [ft]	Chain Weight [lbs/ft]	Dimension H [inches]	Estimated Unit Weight Wo Chain [lbs]	
					SB	DB
4x11	1/2	52	0.25	20 1/2	24	27
		65		22 1/2	24	27
		98		28 1/8	24	27
Dimension M [inches]					12 1/8	13 1/2

SB : Single Brake  
DB : Double Brake