

MAX LOAD = 1/2TON - 2 FALLS - BODY DOWN - HOOK SUSPENSION

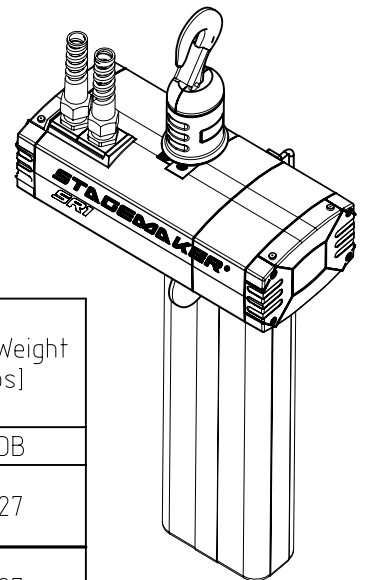
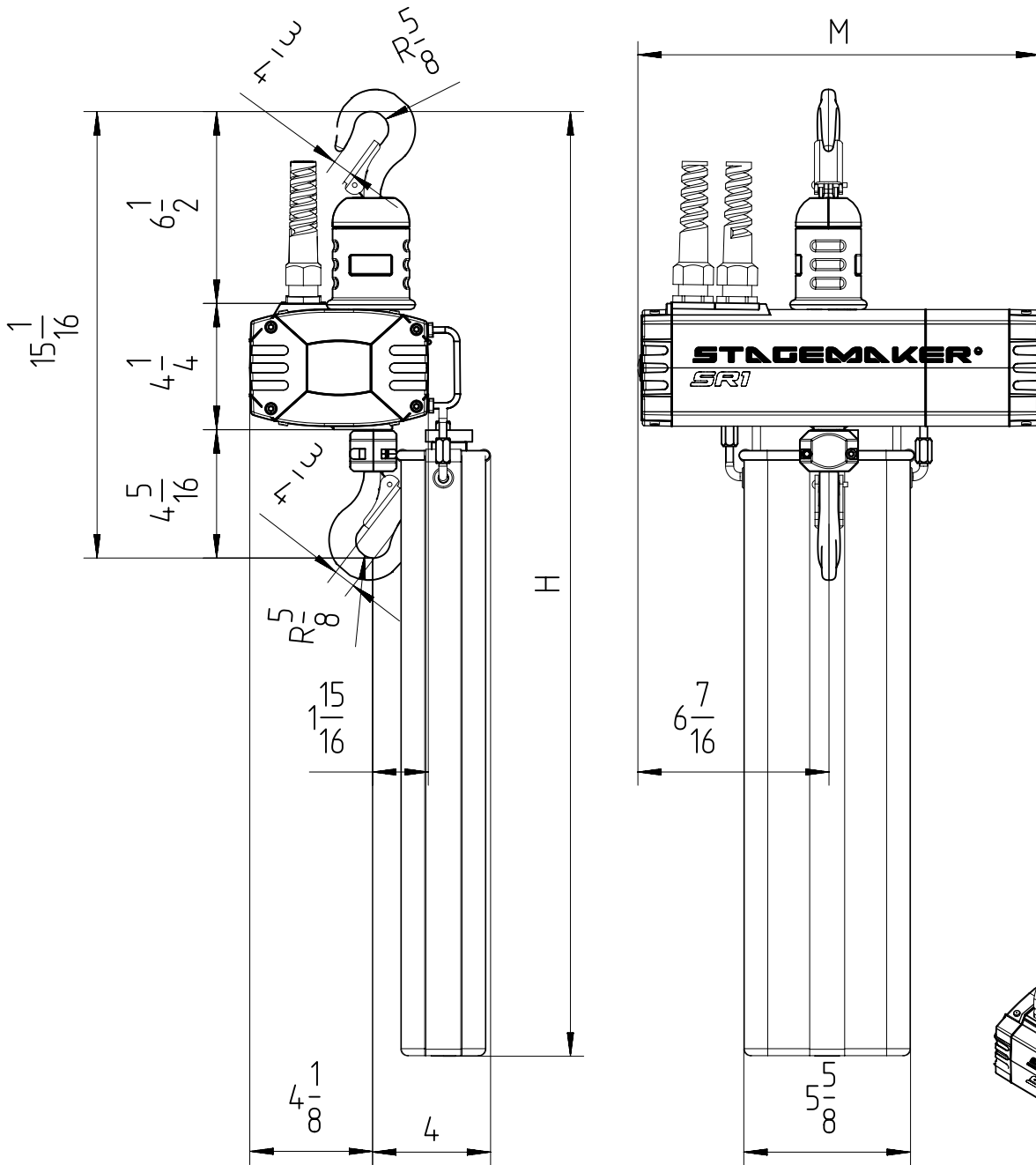

Chain Size	Max Load [ton]	Chain Bag Capacity [ft]	Chain Weight [lbs/ft]	Dimension H [inches]	Estimated Unit Weight W/o Chain [lbs]	
					SB	DB
4x11	1/2	52	0.25	23 3/4	25 1/8	27
		65	0.25	25 3/4	25 1/8	27
		98	0.25	31 3/16	25 1/8	27
Dimension M [inches]					12 1/8	13 1/2

SB : Single Brake
DB : Double Brake