

MAX LOAD = 250KG - 1 FALL - BODY UP - HOOK SUSPENSION

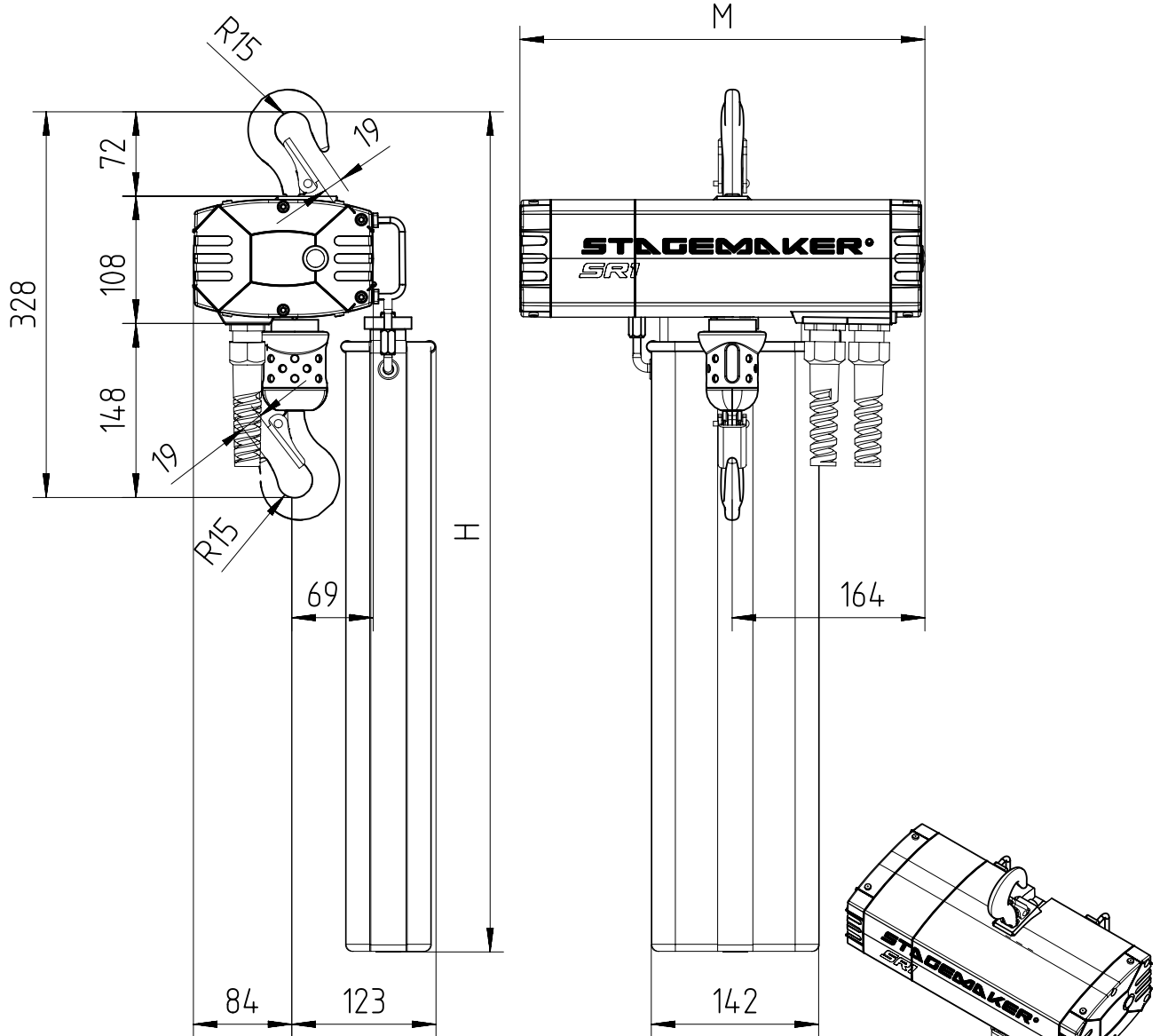

Chain Size	Max Load [kg]	Chain Bag Capacity [m]	Chain Weight [kg/m]	Dimension H [mm]	Estimated Unit Weight W/o Chain [kg]	
					SB	DB
4x11	250	16	0.37	524	10.4	11.7
		20		574	10.4	11.7
		30		715	10.4	11.7
Dimension M [mm]					307	343

SB : Single Brake
DB : Double Brake