

MAX LOAD = 500KG - 2 FALLS - BODY UP - HOOK SUSPENSION

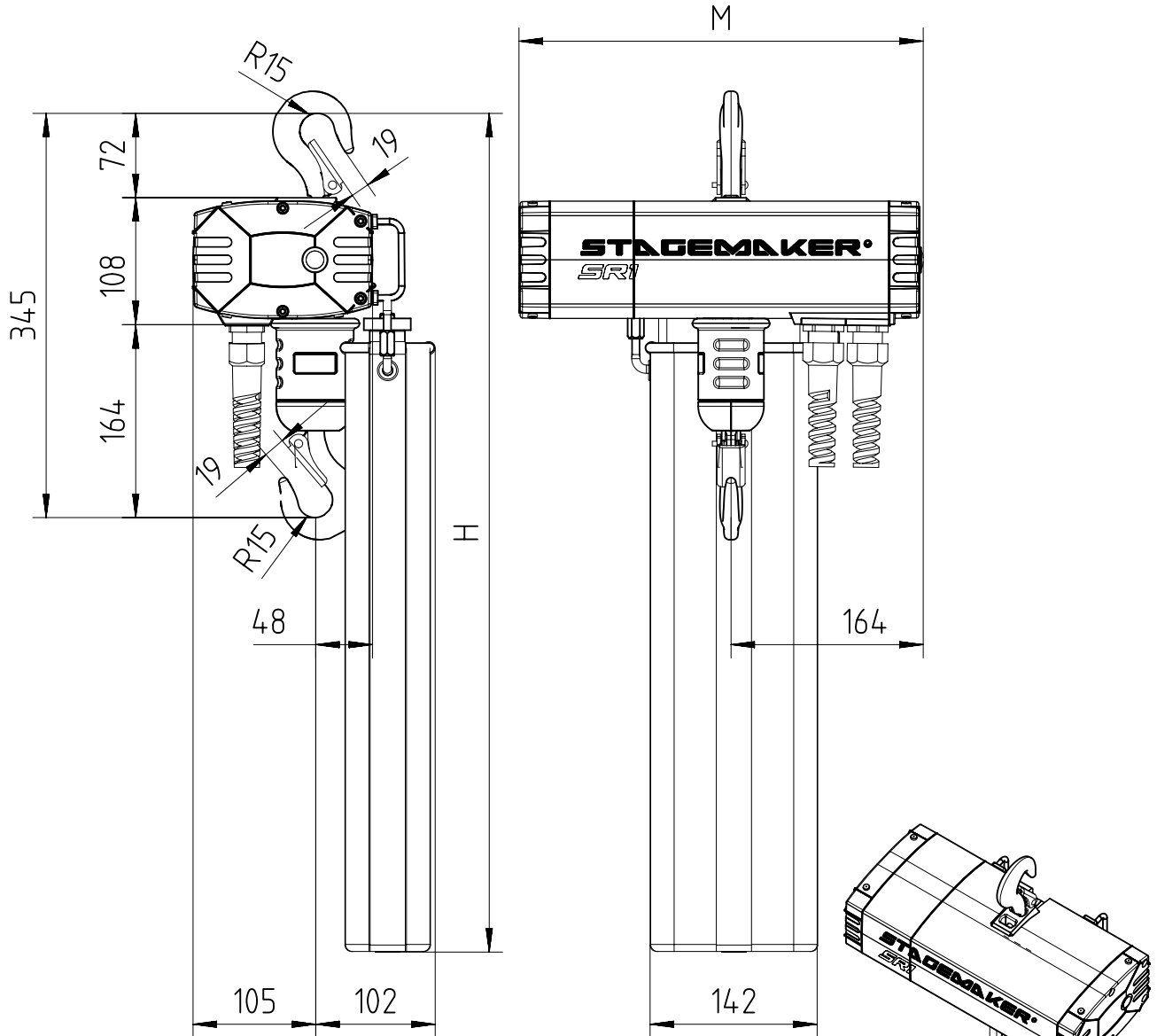

Chain Size	Max Load [kg]	Chain Bag Capacity [m]	Chain Weight [kg/m]	Dimension H [mm]	Estimated Unit Weight W/o Chain [kg]	
					SB	DB
4x11	500	16	0.37	524	11	12.5
		20		574	11	12.5
		30		715	11	12.5
Dimension M [mm]					307	343

SB : Single Brake
DB : Double Brake