

Hook suspended - Body up position

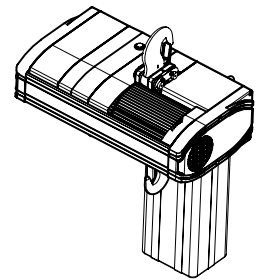
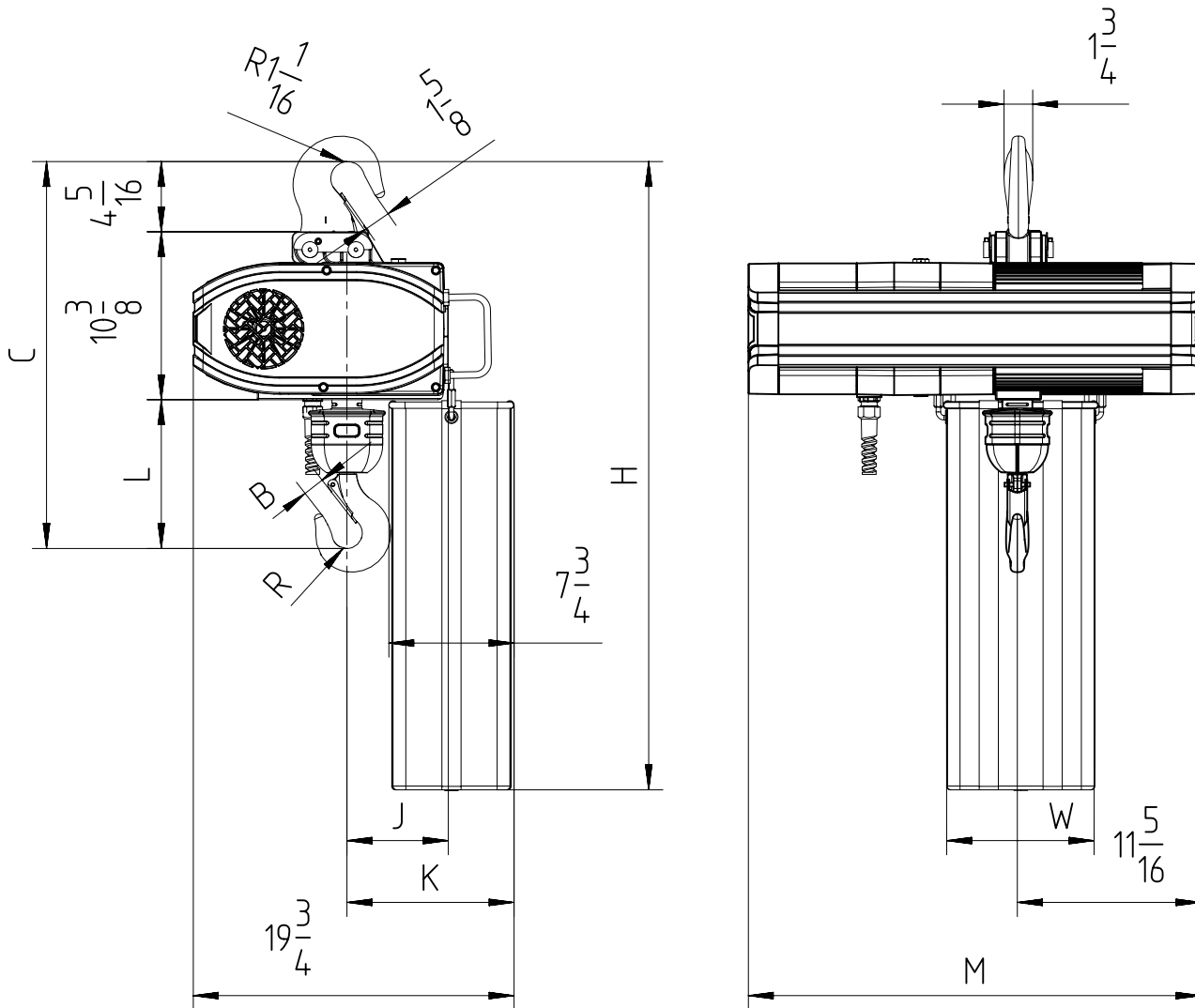

Chain Size (mm)	Max load (Ton)	Falls	Chain bag capacity (ft)	Dimensions (inch)									Weight of chain (lb/ft)	Estimated weight of hoist w/o chain (lb)				
				B	C	L	R	J	K	H	W	M		SB	GLS	DB		
												SB/GLS					DB	
11.3X31	2 1/2	1	65	1 5/16	24 1/16	9 3/8	15/16	6 1/4	10 5/16	39	9 1/8	23 1/8	27 15/16	1.92	265	276	278	
			164							53 9/16	16 1/8							
	5	2	65 (*)	1 5/8	29 15/16	15 1/4	1 1/8	8 3/16	12 1/4	39	9 1/8	23 1/8	27 15/16		1.92	276	287	289
			164 (*)							53 9/16	16 1/8							

SB : Single Brake
DB : Double Brake

(*) In case of 2-fall hoist, available lifting height is half of the chain bag maximum capacity

R&M reserves the right to alter or amend the above information without notice.
R&M se réserve le droit de modifier sans préavis les caractéristiques de son matériel.
R&M behält sich das Recht auf Veränderung oder Richtigstellung der oben genannten Information ohne weitere Mitteilung vor.

53376753
53376753-DRW3
23/08/2016